

REVISIONS				
ZONE	REV.	DESCRIPTION	DATE	APPROVED
	A	INITIAL RELEASE	04-Dec-24	MN

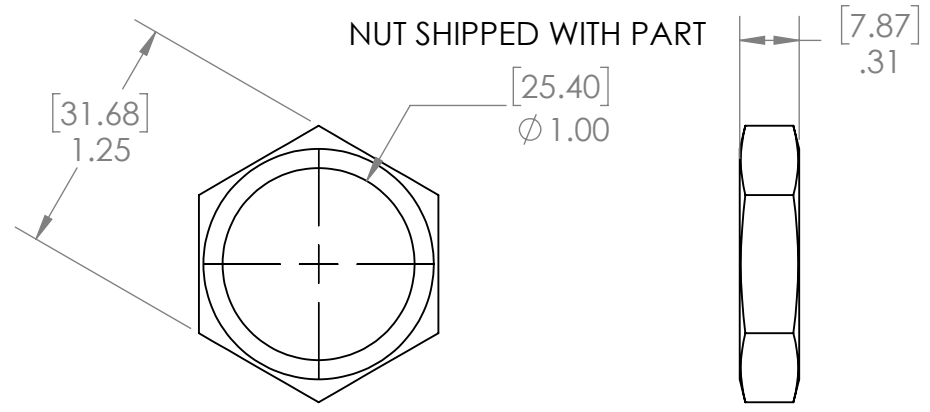

- NOTES:
1. MINIMUM 30 WIRES, RHS RESERVES THE RIGHT TO ADD ONE MORE
 2. HELIUM LEAK TEST @ 1 ATM 1X10⁻⁸ STD-CC/SEC OR BETTER, VACUUM ON THE THREAD SIDE.
 3. PRESSURE LEAK TEST 1,450 PSI THREAD SIDE. NO BUBBLES 3 MINUTES.
 4. HYPOT 300VDC 100 MEGOHMS 1 SECOND MINIMUM CONDUCTOR TO CONDUCTOR AND HOUSING.
 5. SEAL OPERATING TEMPERATURE -20C TO 130C.
 6. ASSEMBLY SHIPPED WITH 304SS JAM NUT (HEX=1.25[31.75] THICKNESS=.30[7.62]).
 7. DIMENSIONS ARE INCHES [MILLIMETERS], MILLIMETERS SHOWN FOR REFERENCE ONLY.
 8. CUSTOM SIZES, WIRE OR FIBER OPTIC CONFIGURATIONS, & TESTS AVAILABLE, PLEASE CONTACT RHS FOR MORE INFORMATION.

UNLESS OTHERWISE SPECIFIED:	NAME	DATE
DIMENSIONS ARE IN INCHES	DRAWN	MN 04-Dec-24
TOLERANCES:	CHECKED	
FRACTIONAL ±1/16	ENG APPR.	
ANGULAR ±.5	MFG APPR.	
X. ±1 .X ±.1	Q.A.	
.XX ±.02 .XXX ±.005	PROPRIETARY AND CONFIDENTIAL	
INTERPRET GEOMETRIC TOLERANCING PER:	THE INFORMATION CONTAINED IN THIS DRAWING IS THE SOLE PROPERTY OF RELIABLE HERMETIC SEALS. ANY REPRODUCTION IN PART OR AS A WHOLE WITHOUT THE WRITTEN PERMISSION OF RELIABLE HERMETIC SEALS IS PROHIBITED.	
MATERIAL	SIZE	DWG. NO.
NOTED	B	63109
FINISH	REV	A
DO NOT SCALE DRAWING	SCALE: 1:1	WEIGHT:
	SHEET 1 OF 1	

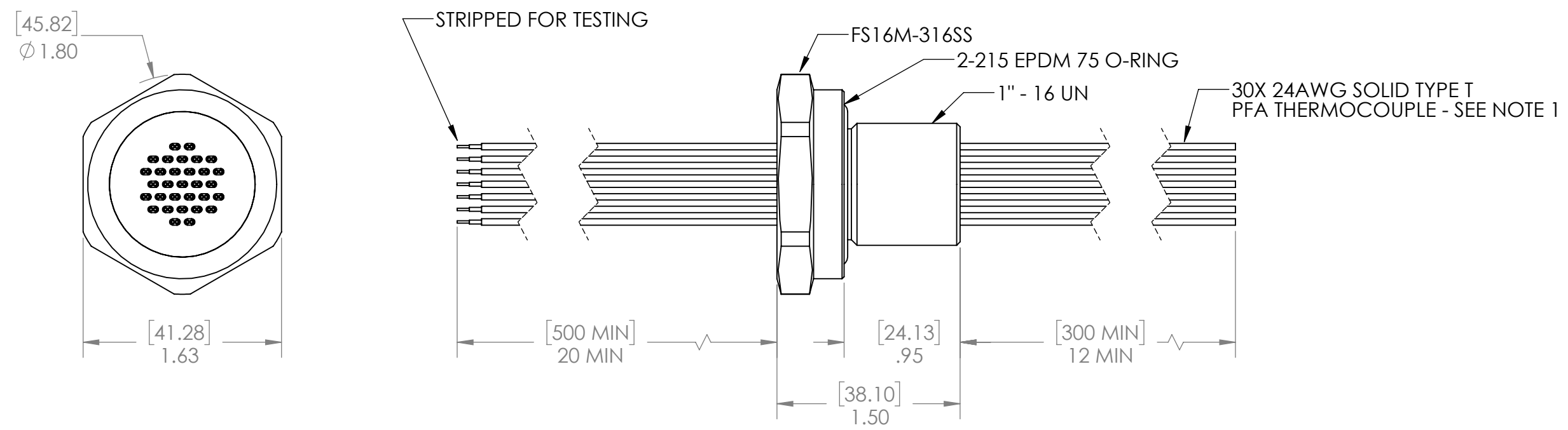

TITLE:
WIRE SEAL FS16M 316SS (30P)24AWG
TYPE T PFA THERMOCOUPLE 30cm-50cm

SCALE: 1:1 WEIGHT: SHEET 1 OF 1